

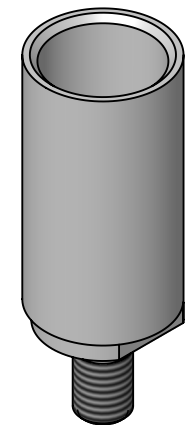

This drawing is the property of MELTRIC Corporation, Franklin (Milwaukee), Wisconsin, USA. Any unauthorized copying of this drawing by any means, ENG/RD/06 REV: 20 ISSUED DATE: 1/15/11 or disclosure of its contents to any person not authorized by MELTRIC Corporation or its agents to receive it, is strictly prohibited.

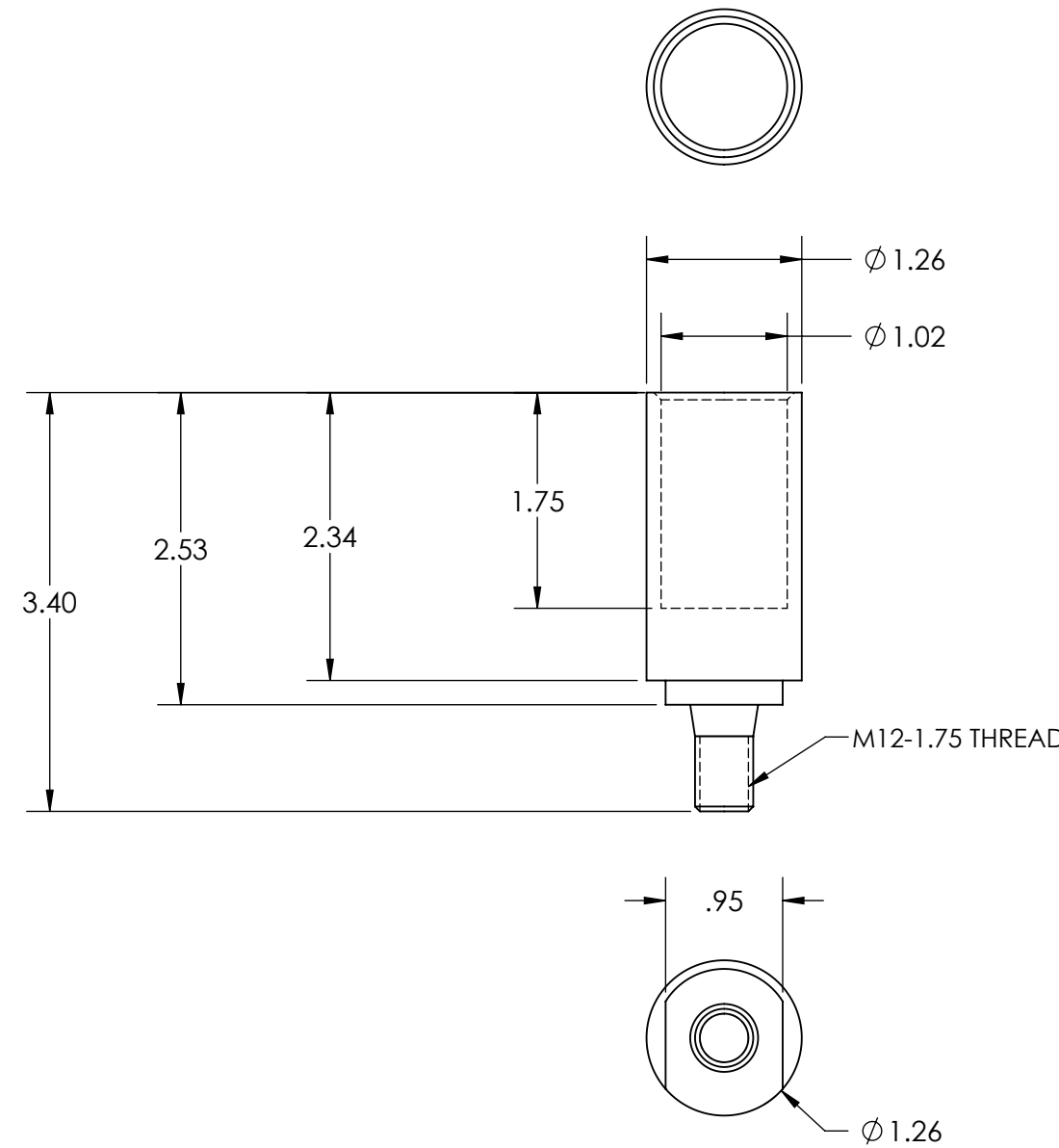

TOLERANCES UNLESS OTHERWISE SPECIFIED	
MACHINED SURFACES $\sqrt[125]{\text{MAX}}$	ENGLISH $0.X \pm 0.05$ $0.XX \pm 0.01$ $0.XXX \pm 0.005$
GROUND SURFACES $\sqrt[32]{\text{MAX}}$	
ANGLE TOLERANCE $\pm 1^\circ$	
REMOVE BURRS & SHARP EDGES TO .015 MAX.	
 DIMENSIONS SHOWN IN OVALS ARE INSPECTION DIMENSIONS.	

		DRAWING TITLE:	
DRAWN	APPROVED	SP STRAIGHT FERRULE FOR 600MCM CABLE	
DATE:		SCALE	MATERIAL:
		NTS	METAL
SHEET: 1 OF 1		PART NUMBER	REVISION
		45-4A30D	